

Also for use with Hammer Unions.
Unions not included.

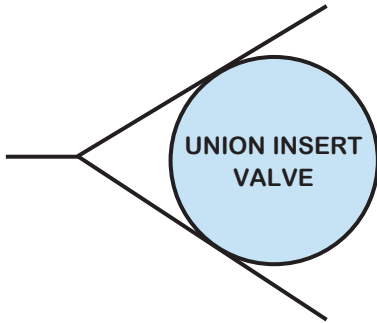

Standard flow configuration.



Reverse trim configuration.

The **Union Insert (UV)** check valve is the threaded pipe counterpart of the Flange Insert check valve. Designed to be inserted into most standard and hammer type ground joint unions, it provides the simplest and most economical way to install a check valve in a threaded pipe system. A check valve may be installed anywhere in the system where there is a union. The valve works equally well in either a horizontal or vertical position with proper spring selection. Each Union Insert valve is furnished with a **metal tag**, which is quickly attached to the union after the valve is installed. This provides a **permanent visual** notification that the union contains a check valve. The UV valve can also be used as a low pressure relief valve or vacuum breaker by using the desired spring settings.

NOTE: Bore of union must be equal to I.D. of schedule 40 pipe. Use ground joint unions with 45° seat only (union not included).

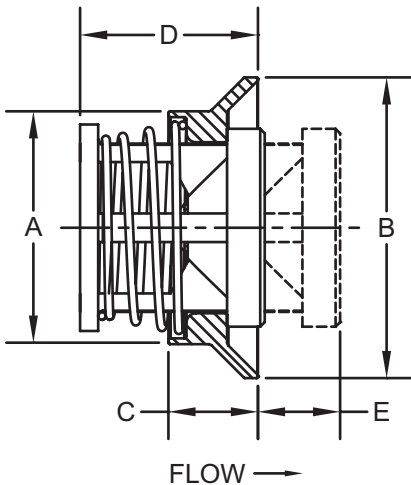

Nom. Pipe Size	Size Code	A	B	C	D	E ¹	Orifice Diameter
1/2	D	0.592	0.937	0.41	0.78	0.41	0.348
3/4	F	0.794	1.125	0.41	0.81	0.44	0.464
1	H	1.000	1.437	0.46	1.09	0.56	0.593
1-1/4	I	1.365	1.750	0.56	1.19	0.70	0.890
1-1/2	J	1.550	2.000	0.60	1.32	0.80	1.135
2	K	2.005	2.500	0.67	1.57	0.92	1.385

¹ Maximum nominal dimension for a fully open valve with no spring.

Body Material ²	Availability	Non-Shock Pressure-Temp. Rating @ 100°F Consult factory for P-T rating above 100° F
316 Stainless Steel (SS)	Standard	3000 PSIG (1500 PSIG for o-ring seats)
Carbon Steel (CS)		
Brass (BR)		
Alloy 20 (A2)	Semi-standard	
Alloy C-276 (HC)		
MONEL® 400 or Alloy R405(MO)	Contact the factory for these or other materials	
Alloy B (HB)		
Titanium (TI)		

² See page 58 for material grade information.

Union Insert Valve
For Water at 72°F

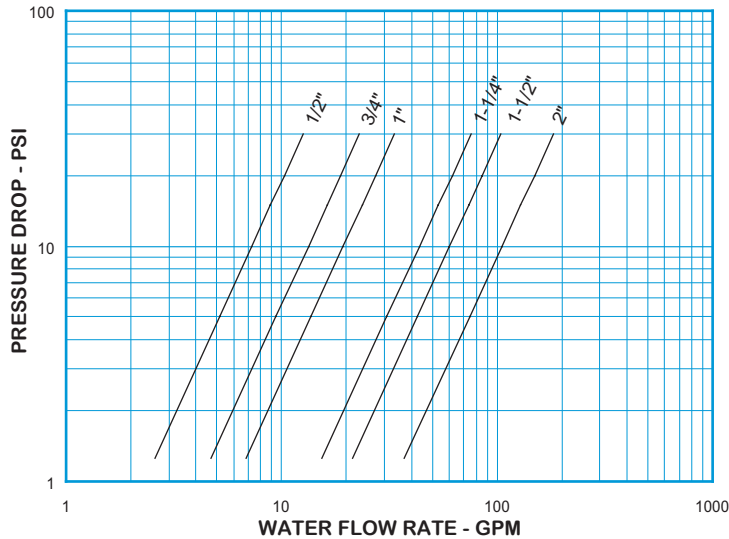

Note: All flow curves and Cv values presume the valves are fully open with 1/2 PSI cracking pressure springs. Consult the factory for more information.

STYLE UV C _v VALUES & VALVE WEIGHTS		
C _v	SIZE	ALL MATL
2.3	1/2	0.5 oz.
4.2	3/4	0.8 oz.
6.1	1	1.6 oz.
13.8	1-1/4	2.8 oz.
19.0	1-1/2	4.3 oz.
33.3	2	7.8 oz.

See page 53 for Flow Formulae.
Valve weights are approximate.

**HOW TO ORDER
CHECK-ALL STYLE UV**

BODY MATERIAL

ALLOY 20 = A2
BRASS = BR
CARBON STEEL = CS
ALLOY B = HB
ALLOY C-276 = HC
MONEL[®] 400 OR ALLOY R405 = MO
316 SS = SS
TITANIUM = TI

See p. 3 for temperature ratings

SPRING CRACKING PRESSURES (PSI)
Must use decimal as a character unless selecting NO SPRING. *Specify Exact Setting*

SPRING RANGES	EXAMPLE
.000 TO .999	= .500
1.00 TO 9.99	= 1.50
10.0 TO 85.0	= 15.0
NO SPRING	= NOSPRG

STANDARD CRACKING PRESSURES ①

.125	.500	1.50	3.50
------	------	------	------

(Sizes D-J Only)

Note: Many other cracking pressures are available. All spring tolerances +/- 15%.

SPECIAL OPTIONS

RT = Reverse trim
(Checks flow in opposite direction)

T = FEP ENCAPSULATED SPRING
Contact the factory for more options

See p. 4 for temperature rating

UV

VALVE STYLE

SIZE

1/2 = D
3/4 = F
1 = H
1-1/4 = I
1-1/2 = J
2 = K

SEAT MATERIAL ②

AFLAS[®] = AS
BUNA-N = BN
EPDM ③ = EP
KALREZ[®] (FFKM) = KZ
FLUOREZ[®] (FFKM) = FZ
"METAL-TO-METAL" = MT
NEOPRENE = NE
PTFE = TF
FKM = VT

See p. 3 for temperature ratings

SPRING MATERIAL

316 SS = SS
ALLOY C-276 = HC
INCONEL[®] X750 OR ALLOY X750 = IX
MONEL[®] 400 = MO
17-7PH SS = PH
TITANIUM = TI

See p. 4 for temperature ratings

Listed above are the most common material selections. Please contact the factory for additional options.

① .500 PSI is the only standard cracking pressure for spring materials other than Stainless Steel. 0.125 PSI springs are not recommended for installations with flow vertical down.

② Seat materials other than "metal-to-metal" have a maximum pressure rating of 1500 PSI. "Metal-to-Metal" and PTFE seats are not resilient. See page 54 for allowable leakage rates.

③ EP seats not recommended for use with Carbon Steel valves.