

Valve shown in flanges.  
Flanges not included.

**Flange Insert** valves are the ultimate check valves in flanged systems. They provide the simplest most economical way to install check valves in a piping system. The valve body automatically positions the valve and holds it in place while bolts are being installed and tightened. All that is required is two gaskets in place of the one normally used in a flanged joint. See page 48 or consult the factory for additional installation guidelines.

**Flange Insert** valves are designed to fit between two mating ANSI flanges. The “Spring Housing”, designated by the “A” dimension, is designed to be inserted into the upstream pipe, thereby centering it in the pipe. Therefore, there must be clearance between the spring housing and the pipe or flange. Generally speaking, the FIV Class 150 and 300 valves (F1) are designed for standard schedule pipe or Class 150 or 300 flanges, and the FIV Class 600 (F6) valves are designed for schedule 80 pipe or Class 600 flanges.

**Flange Insert** valves can be used as check valves, low pressure relief valves, and vacuum breakers by simply using different spring settings.

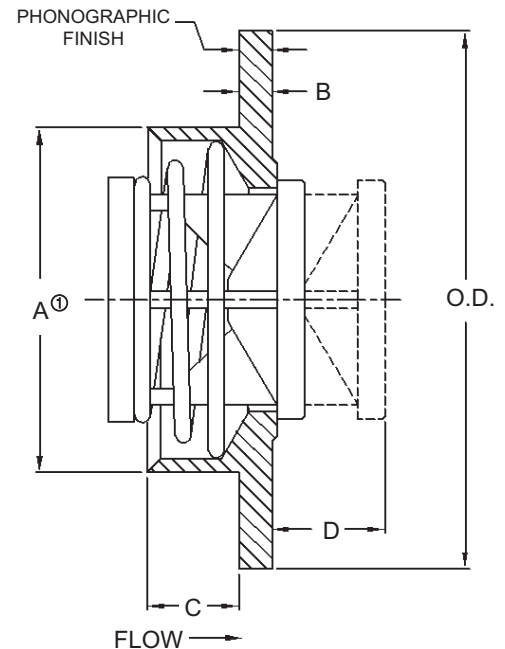

Body Material <sup>②</sup>	Nominal Pipe Size	Non-Shock Pressure Rating		
		ANSI Class 150	ANSI Class 300	ANSI Class 600
316 Stainless Steel (SS) Carbon Steel (CS) Alloy 20 (A2) Hastelloy® C (HC) Hastelloy® B (HB) Mone® (MO) Titanium (TI)	1/2 - 4	X	X	X
	5 - 20	X		
	1/2 - 4	X	X	
	5 - 20	X		
	PTFE (TF)	1/2 - 1-1/2	55 PSIG @ 100°F <sup>③</sup>	
	2 - 6	20 PSIG @ 100°F <sup>③</sup>		
PVC (PV)	1/2 - 6	200 PSIG @ 100°F <sup>③</sup>		

<sup>①</sup>Check “A” dimension for clearance with pipe ID. Generally “A” dimension is designed for use in standard schedule pipe for class 150 & 300 valves (F1). Order class 600 (F6) valves for schedule 80 pipe.

<sup>②</sup>See page 50 for material grade information.

<sup>③</sup>Consult the factory for reduced P-T rating above 100°F. Standard spring material is 316 Stainless Steel.

# HOW TO ORDER CHECK-ALL STYLE FIV (F1, F6, FP)

BODY MATERIAL	
ALLOY 20	= A2
BRASS	= BR
CARBON STEEL	= CS
HASTELLOY® B	= HB
HASTELLOY® C	= HC
MONEL®	= MO
PVC	= PV
316SS	= SS
PTFE	= TF
TITANIUM	= TI

**See p. 4 for Temperature ratings**

SPRING CRACKING PRESSURES			
Replace "X" with actual desired setting. Must use decimal as a character.			
(PSI)	FORMAT		
0.000 TO 0.999	= .XXX		
1.00 TO 9.99	= X.XX		
10.0 TO 99.9	= XX.X		
NO SPRING	= NOSPRG		
STANDARD CRACKING PRESSURES <sup>①</sup>			
.125	.500	1.50	3.50
(Sizes D-N Only)	(Sizes D-N Only)	(Sizes D-J Only)	(Sizes D-J Only)

**Note: Many other cracking pressures are available. Consult factory.**

SPECIAL OPTIONS
T = FEP ENCAPSULATED SPRING
<b>See p. 5 for Temperature rating</b>
Contact the factory for more options



VALVE STYLE
Class 150 & 300 = F1 (FIT UP TO SCH 40 PIPE)
Class 600 = F6 (FIT UP TO SCH 80 PIPE)
PTFE & PVC = FP

SIZE (SEE BELOW)
---------------------

SEAT MATERIAL <sup>②</sup>	
AFLAS®	= AS
BUNA-N	= BN
EPDM	= EP
KALREZ®	= KZ
"METAL-TO-METAL" <sup>③</sup>	= MT
NEOPRENE	= NE
PTFE	= TF
VITON®	= VT

**See p. 4 for Temperature ratings**

SPRING MATERIAL	
316 SS	= SS
HASTELLOY® C	= HC
HASTELLOY® B	= HB
INCONEL® X-750	= IX
MONEL®	= MO
17-7PH SS	= PH
TITANIUM	= TI

**See p. 5 for Temperature ratings**

STYLE F1 (All Metals) SIZES	
1/2	= D
3/4	= F
1	= H
1-1/4	= I
1-1/2	= J
2	= K
2-1/2	= L
3	= M
4	= N
5	= O
6	= P
8	= Q
10	= R
12	= S
14	= T
16	= U
18	= V
20	= W

STYLE F6 (Except Brass) SIZES	
1/2	= D
3/4	= F
1	= H
1-1/4	= I
1-1/2	= J
2	= K
2-1/2	= L
3	= M
4	= N

STYLE FP (PTFE or PVC Only) SIZES	
1/2	= D
3/4	= F
1	= H
1-1/4	= I
1-1/2	= J
2	= K
3	= M
4	= N
6	= P

**Note: Consult the factory for an optional Flag Tag which indicates that a check valve is present in the line.**

Listed above are the most common material selections. Please contact the factory for additional options.

<sup>①</sup>.500 PSI is the only standard cracking pressure for spring materials other than Stainless Steel. Cracking pressure tolerance is +/- 15%. .125 PSI springs are not recommended for installations with flow vertical down.  
<sup>②</sup>PTFE seats are not resilient. See page 47 for allowable leakage rates.  
<sup>③</sup>For plastic valves, seat is the same as body.

See Diagram on Page 6

**FIV (F1, F6, FP) Dimensions**

Nominal Pipe Size	Size Code	ANSI Rating & Material	A	B	C	D <sup>①</sup>	O.D.	Orifice <sup>②</sup> Diameter
1/2	D	150 & 300 600 PTFE & PVC	0.605 N/A 0.600	1/4	0.26 N/A 0.27	0.53	1-3/8	0.348
3/4	F	150 & 300 600 PTFE & PVC	0.762 0.719 0.720	1/4	0.26 0.24 0.26	0.61	1-3/4	0.464
1	H	150 & 300 600 PTFE & PVC	1.000 0.922 0.930	1/4	0.36 0.32 0.36	0.78	2	0.593
1-1/4	I	150 & 300 600 PTFE & PVC	1.340 1.234 1.240	1/4	0.44 0.39 0.44	0.85	2-1/2	0.890
1-1/2	J	150 & 300 600 PTFE & PVC	1.570 1.490 1.490	1/4	0.44 0.40 0.50	1.01	2-7/8	1.135
2	K	150 & 300 600 PTFE & PVC	2.005 1.890 1.890	1/4	0.49 0.43 0.52	1.19	3-5/8	1.385
2-1/2	L	150 & 300 600	2.407 2.266	1/4	0.66 0.59	1.43	4-1/8	1.555
3	M	150 & 300 600 PTFE & PVC	3.006 2.844 2.865	5/16	0.70 0.64 0.73	1.59	5	2.025
4	N	150 & 300 600 PTFE & PVC	3.964 3.766 3.766	3/8	1.00 0.96 1.00	1.91	6-3/16	2.560
5	O	150	4.985	1/2	1.07	2.12	7-5/16	3.280
6	P	150 PTFE & PVC	6.003 5.700	3/8 9/16	1.52 1.55	2.46	8-1/2	3.875
8	Q	150	7.919	1/2	2.27	3.30	10-5/8	5.110
10	R	150	9.958	1/2	2.84	3.47	12-3/4	6.380
12	S	150 Brass Other Metals	11.876	5/8 1/2	3.12 3.24	4.14	15	7.670
14	T	150 Brass Other Metals	13.062	11/16 1/2	3.18 3.37	4.42	16-1/4	8.460
16	U	150 Brass Other Metals	14.938	3/4 9/16	3.69 3.88	5.02	18-1/2	9.650
18	V	150 Brass Other Metals	16.814	7/8 5/8	3.87 4.12	5.60	21	10.860
20	W	150 Brass Other Metals	18.750	15/16 11/16	3.88 4.13	6.23	23	12.110

① Maximum nominal dimension for a fully open valve with no spring.

② Due to molding process, orifice in plastic valves may vary.

Sizes 5" and larger are only available in class 150. Consult the factory if using Schedule 80 pipe.

**Flange Insert**  
Flow Curves assume Schedule 40 pipe  
For Water at 72°F

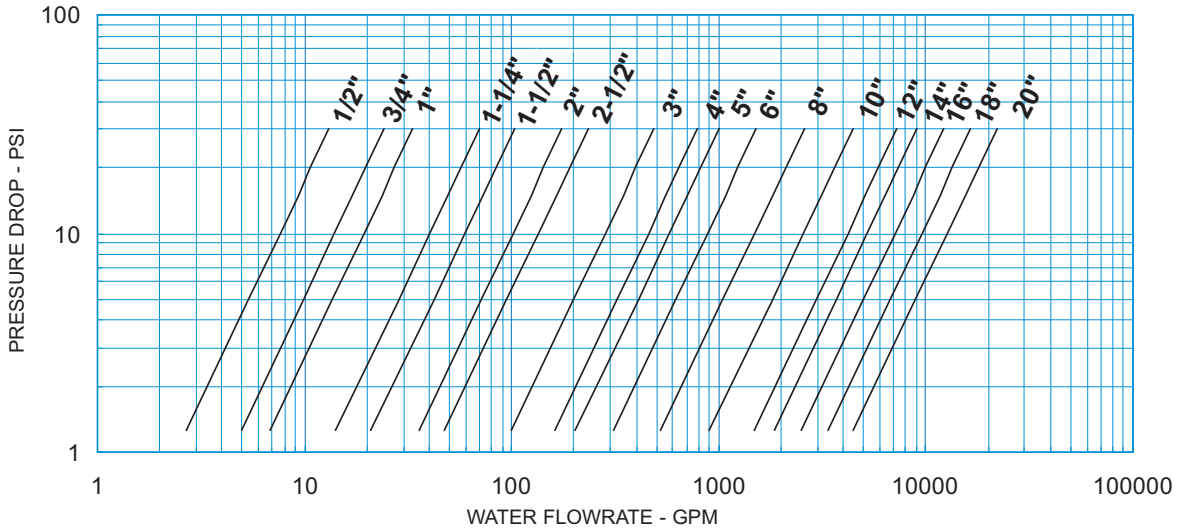

**Note:** All flow curves and Cv values presume the valves are fully open with 1/2 PSI cracking pressure springs. Consult the factory for more information.

STYLE FIV (F1, F6, FP) C <sub>v</sub> VALUES & VALVE WEIGHTS					
C <sub>v</sub>	SIZE	SS & CS	BRASS	PTFE	PVC
2.4	1/2	1.7 oz.	1.9 oz.	0.5 oz.	0.3 oz.
4.4	3/4	2.9 oz.	3.2 oz.	0.8 oz.	0.5 oz.
6.1	1	4.2 oz.	4.6 oz.	1.1 oz.	0.7 oz.
12.7	1-1/4	7.0 oz.	7.4 oz.	1.9 oz.	1.4 oz.
18.8	1-1/2	9.5 oz.	9.8 oz.	2.6 oz.	1.7 oz.
32.0	2	16.3 oz.	17.3 oz.	3.8 oz.	2.6 oz.
42.5	2-1/2	1.4 lb.	1.5 lb.	---	---
89.0	3	2.3 lb.	2.6 lb.	9.6 oz.	6.1 oz.
144	4	4.5 lb.	4.9 lb.	1.2 lb.	12.7 oz.
182	5	7.8 lb.	8.3 lb.	---	---
277	6	10.4 lb.	11.7 lb.	1.8 lb.	1.2 lb.
470	8	21.2 lb.	26.4 lb.	---	---
810	10	36 lb.	42 lb.	---	---
1320	12	54 lb.	70 lb.	---	---
1650	14	74 lb.	93 lb.	---	---
2230	16	105 lb.	130 lb.	---	---
3010	18	157 lb.	201 lb.	---	---
4000	20	207 lb.	262 lb.	---	---

C<sub>v</sub> values assume Schedule 40 pipe  
See page 46 for Flow Formulae