

The **Connector** valve is a check valve with a hex nipple or connector housing. It is designed to be used in installations where a check valve with male pipe threads are required. The Connector valve is adaptable for use as a check valve, vacuum breaker, or low pressure relief valve. Two valves used in combination make an excellent low pressure relief/vacuum breaker. Also available with ISO 7 “R” threads.

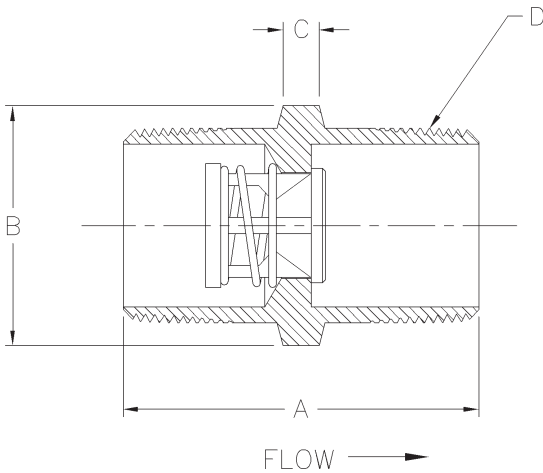

Nom. Pipe Size	Size Code	A	Hex ^① Size B	C	D	Orifice Diameter
1/2	D	2.34	7/8	0.28	1/2 NPT	0.348
3/4	F	2.34	1-1/8	0.27	3/4 NPT	0.464
1	H	3.00	1-3/8	0.35	1 NPT	0.593
1-1/4	I	3.00	1-3/4	0.33	1-1/4 NPT	0.890
1-1/2	J	3.19	2	0.32	1-1/2 NPT	1.135
2	K	3.68	2-1/2	0.38	2 NPT	1.385
2-1/2	L	5.00	3-1/4	N/A	2-1/2 NPT	1.555
3	M	5.50	4	N/A	3 NPT	2.025
4	N	5.00	5	0.61	4 NPT	2.560

^①May be larger and/or round.

Body Material ^②	Availability	Non-Shock Pressure-Temperature Rating	
316 Stainless Steel (SS)	Standard	1/2" - 3" 3000 PSIG @ 100°F (1500 PSIG for o-ring seats)	4" 1500 PSIG @ 100°F
Carbon Steel (CS)			
Brass (BR)			
Alloy 20 (A2)	Semi-standard		
Hastelloy [®] C (HC)			
Mone [®] (MO)			
Hastelloy [®] B (HB)			
Titanium (TI)	Contact the factory for availability of these or other materials		

^②See page 50 for material grade information.

Note: All flow curves and Cv values presume the valves are fully open with 1/2 PSI cracking pressure springs. Consult the factory for more information.

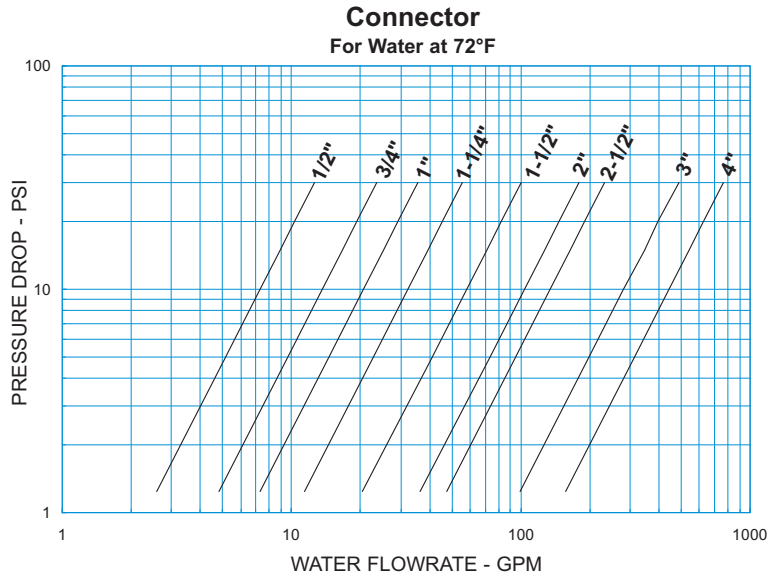

STYLE CON (CN) C _v VALUES & VALVE WEIGHTS		
C _v	SIZE	ALL MATL
2.3	1/2	2.5 oz.
4.3	3/4	3.9 oz.
6.5	1	7.5 oz.
10.2	1-1/4	10.9 oz.
18.3	1-1/2	1.5 lb.
32.7	2	2.7 lb.
42.5	2-1/2	5.0 lb.
89.0	3	8.9 lb.
140	4	10.3 lb.

See page 46 for Flow Formulae

HOW TO ORDER CHECK-ALL STYLE CON (CN)

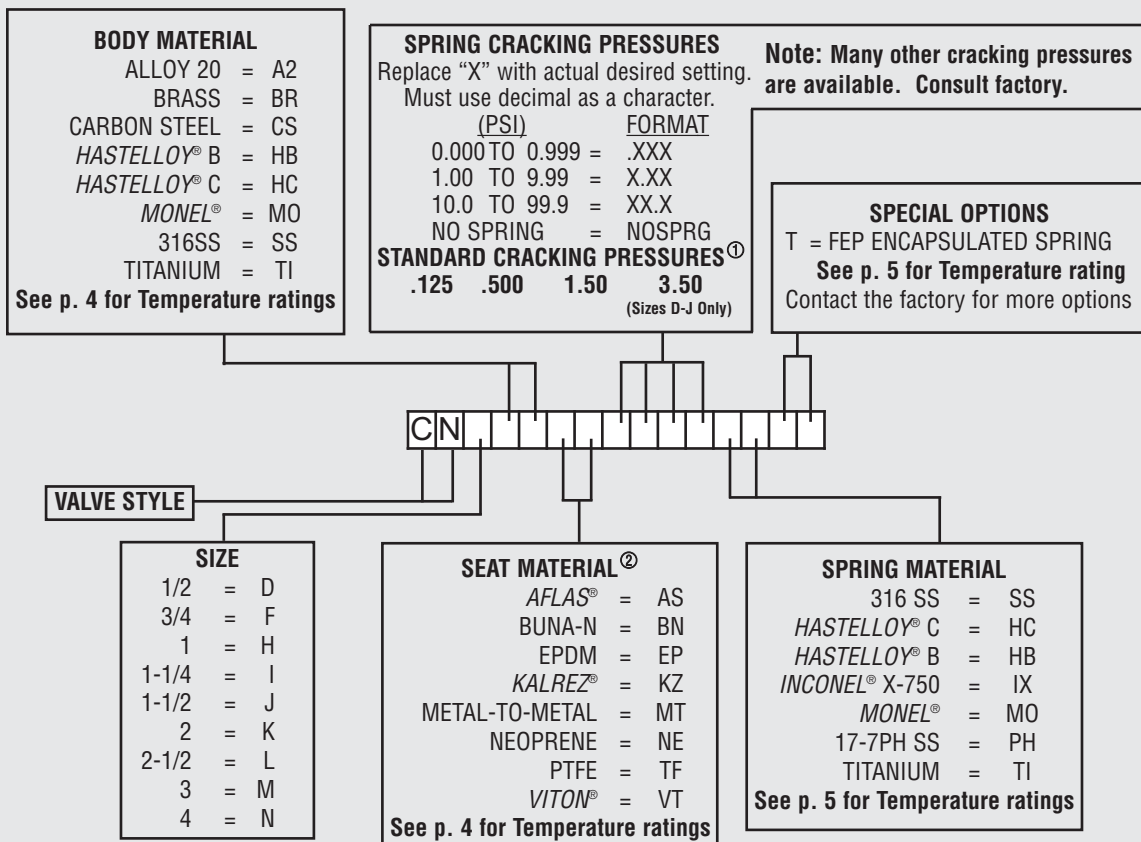

Listed above are the most common material selections. Please contact the factory for additional options.

① .500 PSI is the only standard cracking pressure for spring materials other than Stainless Steel. Cracking pressure tolerance is +/- 15%. .125 PSI springs are not recommended for installations with flow vertical down.

② Seat materials other than metal-to-metal have a maximum pressure rating of 1500 PSI. PTFE seats are not resilient. See page 47 for allowable leakage rates.